



Cloud computing and cake

22 March 2016



@AdaptaforNFP #cloudcomputing

Adapta Consulting

We are:

- A specialist information systems consultancy
- We only work with membership organisations, charities, associations, trusts and others in the NfP sector
- We are completely supplier-independent
- Our consultants have held senior positions in a broad range of different organisations
- Our advice and guidance is based on practical experience gained over many years.

Programme

- 14.00 **Arrival and welcome**
Welcome to the event, introductions and overview of the agenda for the afternoon.
- 14:15 **Overview of cloud-base services available to the sector**
A state of the market summary including a review of the key issues driving nfp organisations to cloud-based services.
- 14:30 **Case studies**
Short stories from speakers
Short practical case studies from speakers who have implemented cloud-based services within their organisation – including what has worked well ...and what has not!
- 15:45 **Discussion and feedback**
All
A round table discussion and feedback.
- 16.30 - **Review and close**
17.00

Cloud Computing

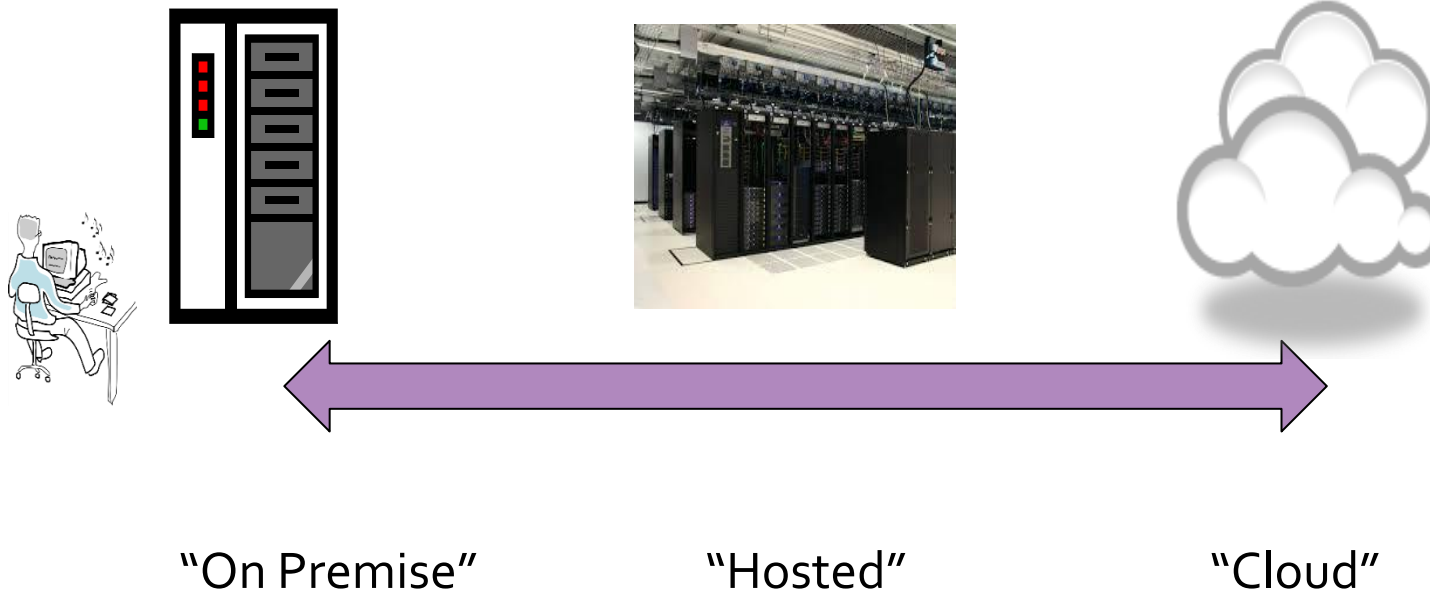

20th Century CRM.....



Marketers



Supporters

21st Century CRM.....

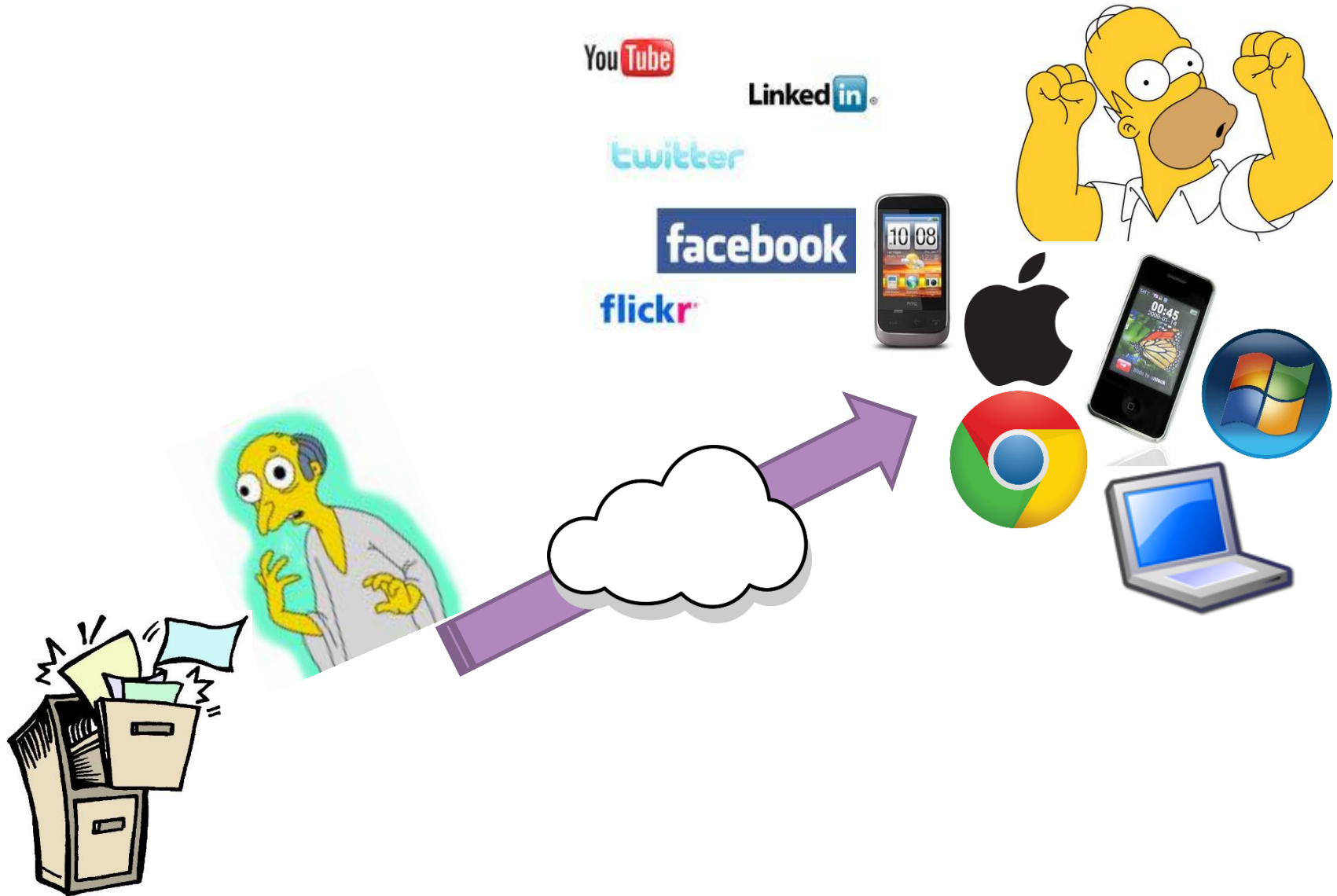

21st Century CRM.....



Office 365



Simeon Lewis

Head of IT

SimeonLewis@worldanimalprotection.org

World Animal Protection

We were known as **WSPA**
(World Society for the
Protection of Animals)

World Animal Protection



Who we are

Global Not for Profit Organisation

Our vision: A world where animals live free from suffering

The world's leading global animal welfare organization

400+ employees, global income of \$67 million

4 Program Areas: Communities, Disasters, Farming and Animals in the Wild

Active in over 50 countries



www.worldanimalprotection.org

Business Challenges



- ▶ Enhance collaborative culture
- ▶ Support remote staff and dispersed teams
- ▶ Improve access to information
- ▶ Make the most of limited resources
- ▶ Rebrand – World Animal Protection
- ▶ No Wide Area Network

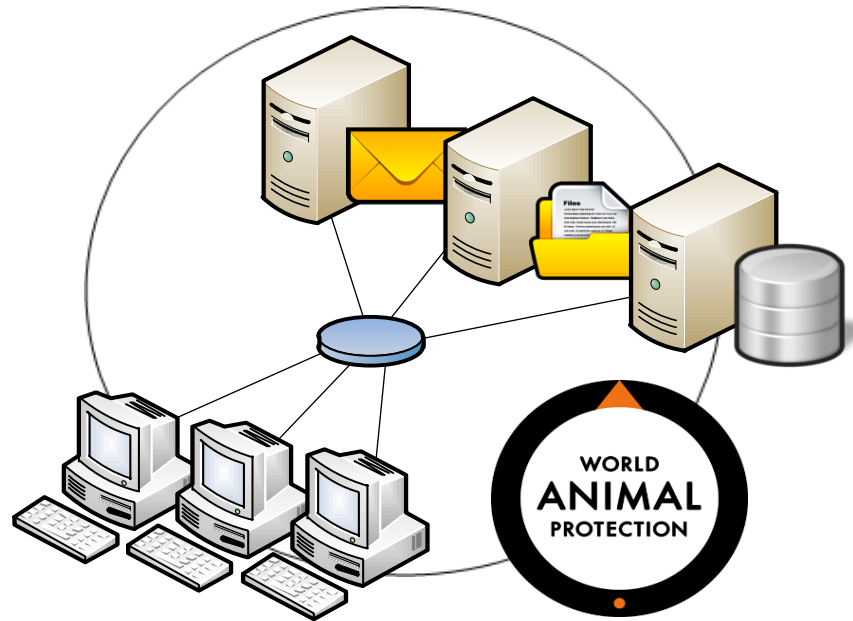

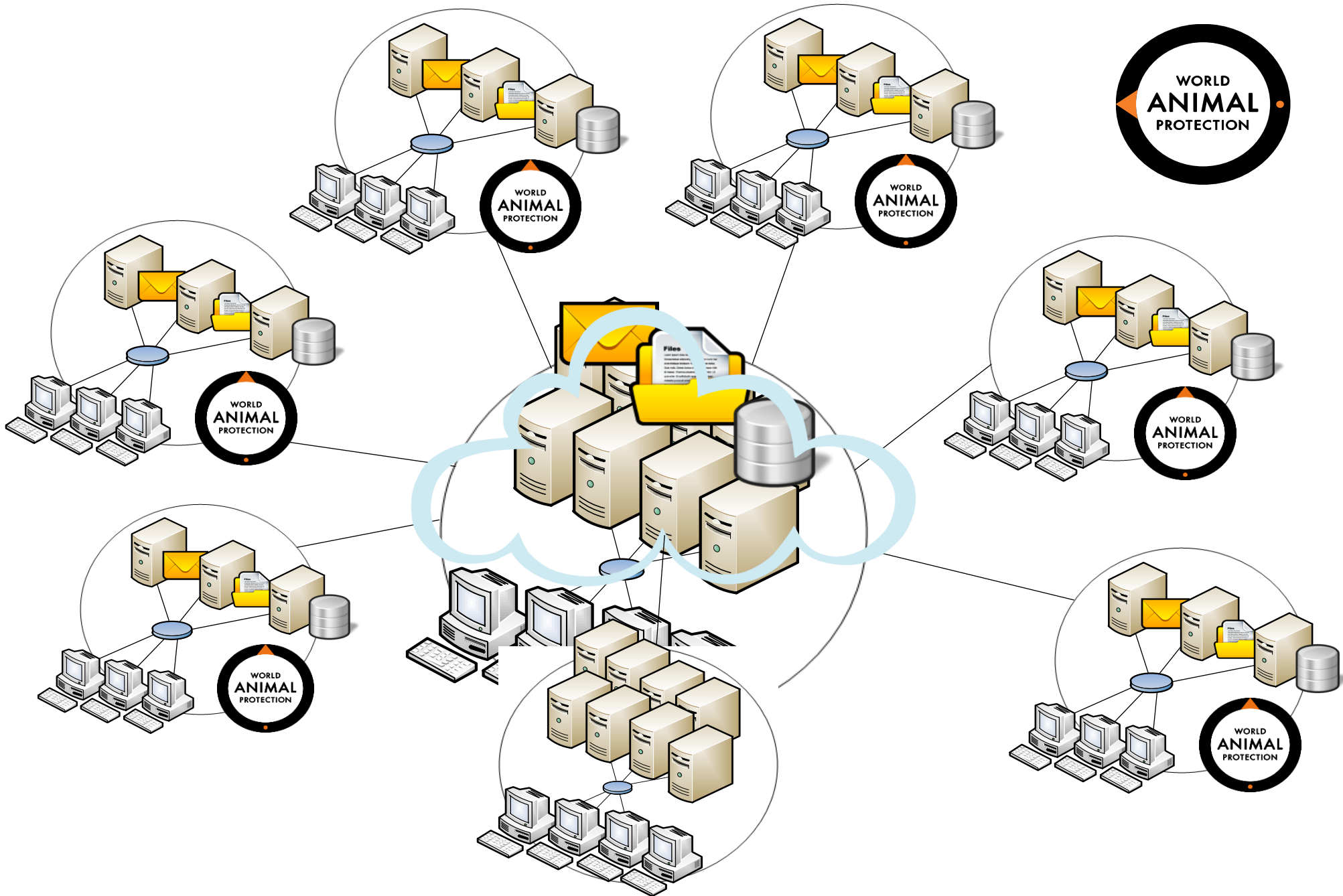



 Microsoft Dynamics CRM

 Office Professional Plus 2013



 OneDrive for Business

 Office 365

 Skype for Business

 SharePoint

 Exchange



 Team Site

 Project Site

 Community



Azure AD Premium

- ▶ Identity and access management
- ▶ Provides cloud write-back capabilities enabling solutions like self-service password reset for your on-premises users.
- ▶ Supports thousands of pre-integrated applications





Questions and Answers

Microsoft Case Study



World Animal Protection | X

→ ↻ 🏠 <https://community.dynamics.com/b/msftdynamicsblog/archive/2016/01/04/world-animal-protection-seeks-to-inspire-global-change-end-animal-suffering>

Microsoft Sales: 1-888-477-7989 Dynamics CRM Sign

Dynamics

Home Solutions ▾ Industries ▾ Partners Support [Blog](#)

World Animal Protection Seeks to Inspire Global Change; End Animal Suffering

 By Kelly Rigotti on 1/4/2016 8:00:00 AM

World Animal Protection and Microsoft Dynamics



World Animal Protection is a global charity, with agencies all over the world. Microsoft Dynamics provides an effortless business solution so WAP can focus on the animals, not the office.

The relationship between animals and mankind is vital. We rely on them and they depend upon us. For over

Interact with this Article

[Sign In](#)

[Share](#) ▾

[RSS](#)

Microsoft Dynamics Blog

The place to go for opinions, news, features and information about business applications from Microsoft.

Browse the Microsoft Dynamics Blog

- [All Blog Articles](#)
- [CRM](#)
- [Customers](#)
- [Enterprise](#)
- [Industries](#)
- [News & Events](#)
- [Small & Midsize Businesses](#)

TECHNOLOGY TRUST

A JOURNEY TO THE CLOUD

Richard Cooper
Technology Trust

tt-mail

Response Marketing

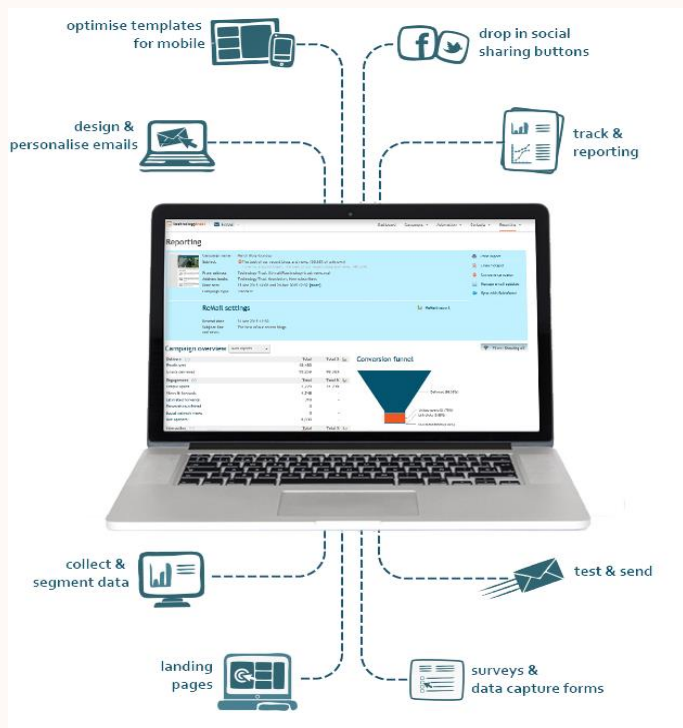

tt-exchange

<p>You can use Adobe products to edit images, design websites, publish newsletters, create videos and audio productions, and more.</p> <p>Adobe products</p> <p>View Adobe partner page</p>	<p>Autodesk's advanced design software can be used to design buildings, infrastructure, products, entertainment content, and more.</p> <p>Autodesk products</p> <p>View Autodesk partner page</p>	<p>Bitdefender Internet Security is security software that protects computers from viruses, spam and other online threats.</p> <p>Bitdefender products</p> <p>View Bitdefender partner page</p>	<p>TechSoup Boost offers a stream of social offers that help them provide you with more of the tools and resources you want for less money over time.</p> <p>Boost products</p> <p>View Boost partner page</p>
<p>You can use Box to manage and collaborate on content with staff members and volunteers and to distribute content to beneficiaries.</p> <p>Box products</p> <p>View Box partner page</p>	<p>UltraKey from Bytes of Learning, systematically teaches touch typing and safe keyboarding using voice, 3D animation, video, and virtual reality. It provides many options that adapt to a broad range of age groups and special needs.</p> <p>Bytes of Learning products</p> <p>View Bytes of Learning partner page</p>	<p>The Cisco Worldwide Programme brings Cisco's best-in-class networking products and technology to qualifying nonprofit organisations.</p> <p>Cisco products</p> <p>View Cisco partner page</p>	<p>Citrix Online is a remote-connectivity tool offering web-based remote access, remote support and web conferencing solutions for individuals and organisations.</p> <p>Citrix Online products</p> <p>View Citrix Online partner page</p>
<p>Eventbrite enables people all over the world to plan, promote and sell out any event. Eventbrite makes it easy for everyone to discover events, and to share the events they are attending with the people they know.</p> <p>Eventbrite products</p> <p>View Eventbrite partner page</p>	<p>Huddle is an online, cloud-based service offering enterprise-level collaboration tools, cloud content management, and team project and task management.</p> <p>Huddle products</p> <p>View Huddle partner page</p>	<p>Mailshell Anti-Spam Toolkit is a desktop-based spam-filtering solution for Windows users that intercepts incoming email messages before they reach the user's inbox.</p> <p>Mailshell products</p> <p>View Mailshell partner page</p>	<p>Microsoft donate over 100 of their most popular software titles to a wide range of UK charities.</p> <p>Microsoft products</p> <p>View Microsoft partner page</p>
<p>O&O Business Suite are system and data management applications for small and medium sized organisations - designed to increase network performance, backup and restore disk images, recover data, and support network administration.</p> <p>O and O Software products</p> <p>View O and O Software partner page</p>	<p>Prodigy Learning is exclusively responsible for managing the Adobe Certified Associate (ACA) and Microsoft Office Specialist (MOS) training and certification programmes throughout the UK and Ireland.</p> <p>Prodigy Learning products</p> <p>View Prodigy Learning partner page</p>	<p>Shopify is a hosted e-commerce service that allows you to set up and run an online store on a new or existing website - with tools for designing a storefront, managing inventory, and accepting online payments.</p> <p>Shopify products</p> <p>View Shopify partner page</p>	<p>Symantec helps consumers and organisations secure and manage their information. Their software and services protect against risks, completely and efficiently, enabling confidence wherever information is used or stored.</p> <p>Symantec Desktop products</p> <p>View Symantec Desktop partner page</p>
<p>Symantec helps consumers and organisations secure and manage their information. Their software and services protect against risks, completely and efficiently, enabling confidence wherever information is used or stored.</p> <p>Symantec Enterprise products</p>	<p>Install Office 365 on your own, with our help. Enrol in our professionally guided self-implementation program for charities moving to Office 365.</p> <p>Tech Impact products</p> <p>View Tech Impact partner page</p>	<p>Office 365</p> <p>Google for nonprofits</p>	

We were here

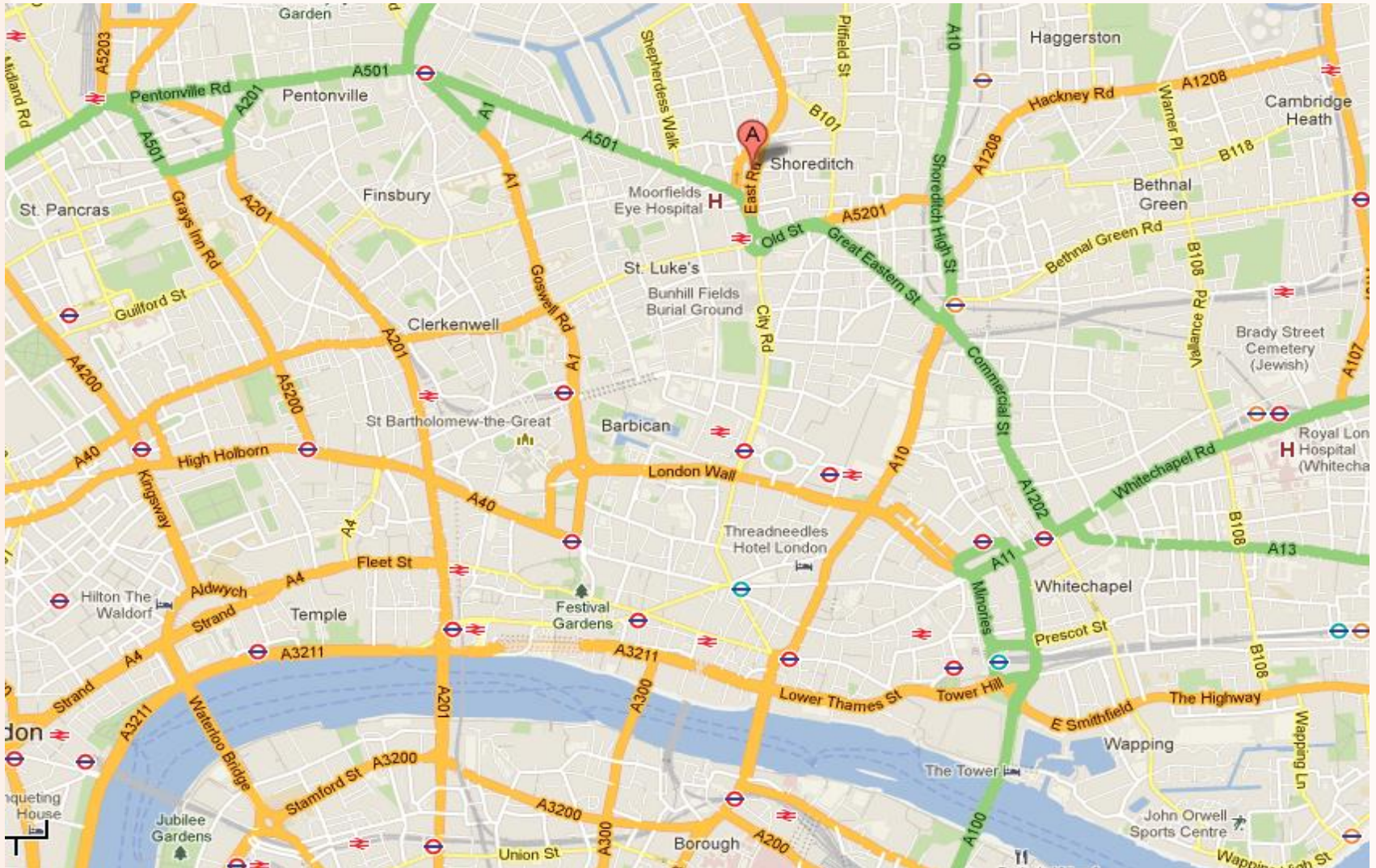

These were the neighbours



London 2012 Olympics: Fears grow of Olympic tube chaos

Fears are growing over the ability of London's tube network to cope during the Olympics after the system suffered another catastrophic morning.



So we moved



Not everyone was happy



More seriously

METRO NEWS... BUT NOT AS YOU KNOW IT
58.3M SHARES

HOME NEWS SPORT ENTERTAINMENT LIFESTYLE MORE

UK WORLD WEIRD TECH

London under mock terror attack today and tomorrow (for 999 exercise)

Rachel Wills for Metro.co.uk Tuesday 30 Jun 2015 10:29 am

1.2k

MUST READ

Helen Mirren says men putting their arm around their girlfriend's shoulders looks like 'ownership'

The Oscar-winning actress said it 'annoys her'.

Kate Middleton shows off new hairstyle in rare public appearance



Cloud drivers

- Disaster recovery
- Flexible working for staff
- Lower costs/ better cost management
- Increased reliability
- Better systems

The beginning of our journey



Internet

Technology Trust Office

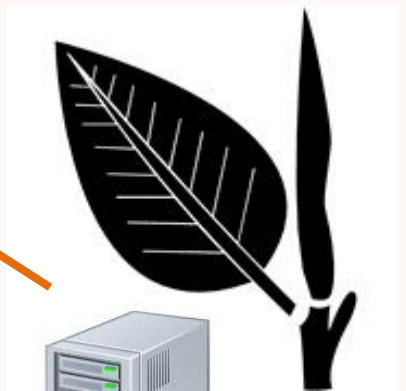
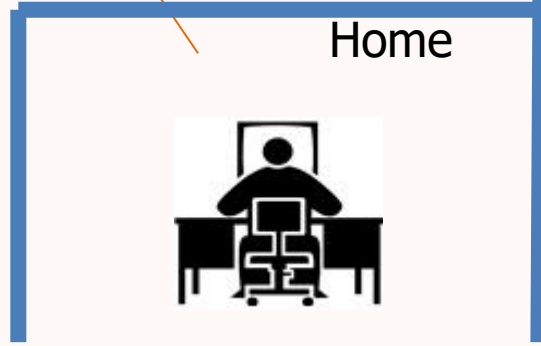

Email Files

Where we were in 2012

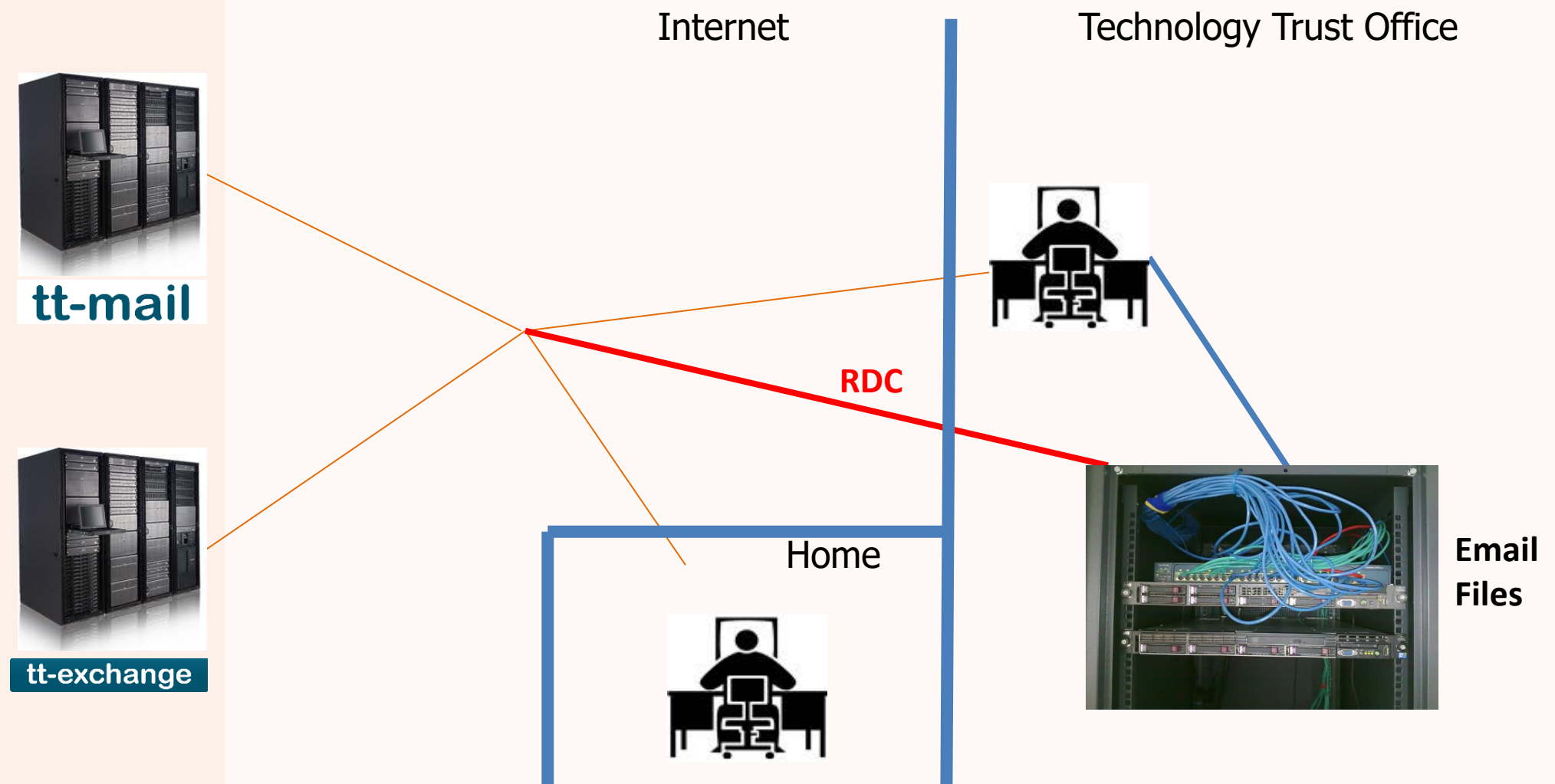

Office 365 – email

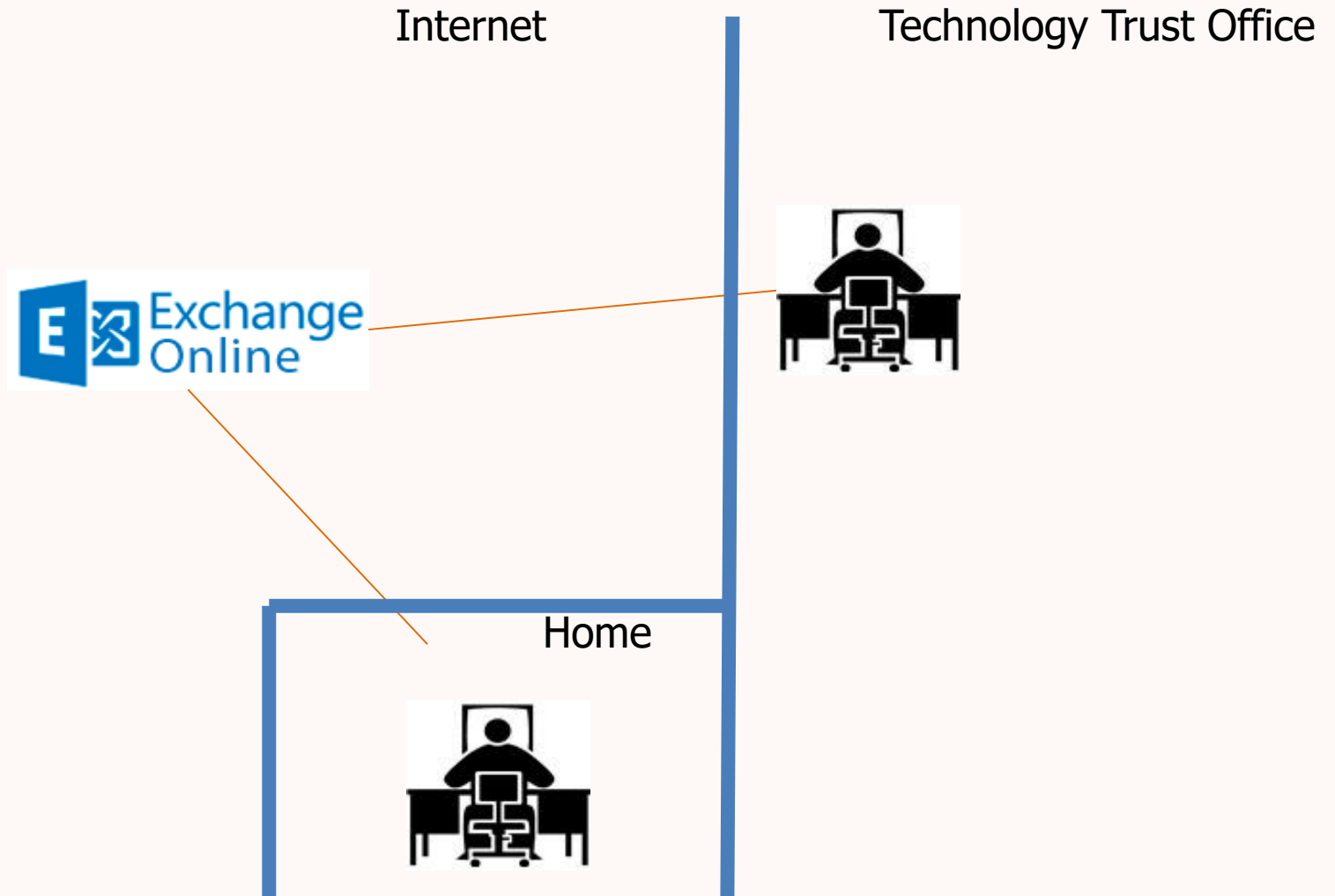

Shared Files

Most secure
• Client Data
• Personal Data
• dpa

Medium secure
• Operational data

Low security
non-dpa
• personal files
• External non-secure



Internet

Technology Trust Office



Home



Telephones – improving client service

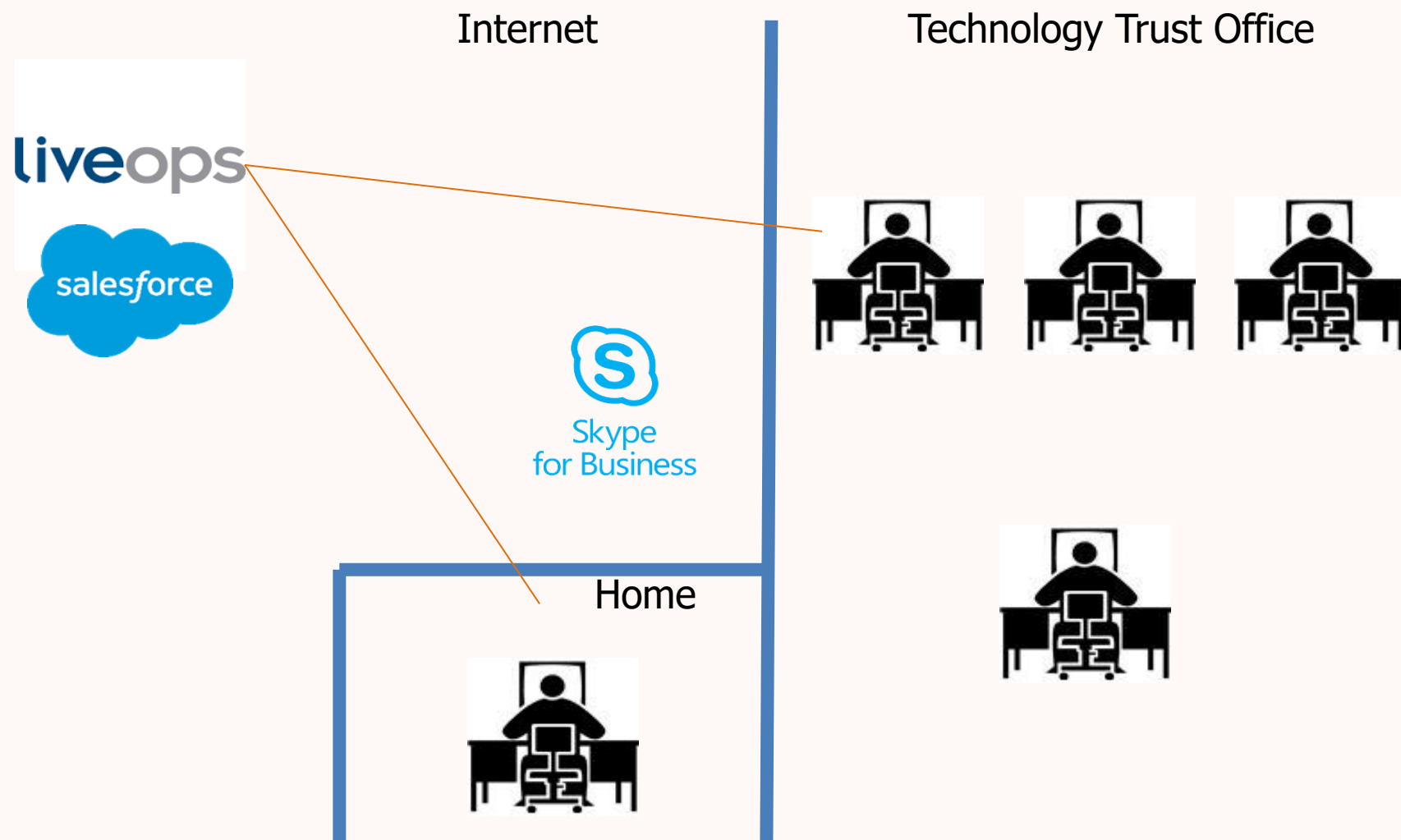

Office unplugged (sort of)



Anywhere with internet



Home



Technology Trust Office



Benefits

- Complete office flexibility
- Easy home working
- Very high reliability
- Massively increased functionality and usability
- Savings on support have offset revenue cost increases
 - Significant decrease in staff time spent on IT problems
- No anticipated capital costs

Learnings

- There are quite a few ways to do this
 - Read the reports (5 best)
 - Try before you buy
- Get as much bandwidth as you can afford into the office
- Identify the full cost of what you have today
- Do it in stages
- Take people with you
- Have a good 'spring clean' of your email and files

One problem we still have to solve



Discussion and feedback



Review and close